

TRUE RMS MULTIMETER/DATA LOGGER

IEC1010-1 1000V CAT III

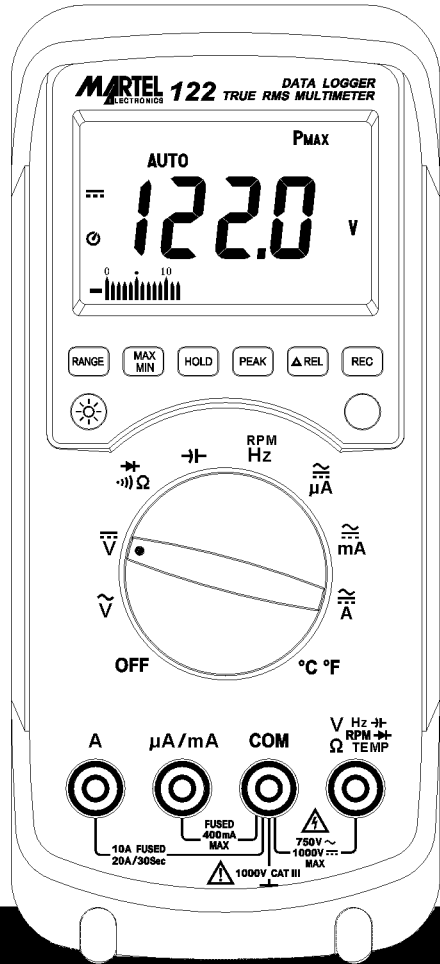

Instruction Manual • RS-232 TestLink SE-120

CONTENTS

Safety Information	1
I. SPECIFICATIONS	1
1.General Information.....	1
2.Electrical Specifications.....	2
II. SYMBOL DEFINITION & BUTTON LOCATION	4
1. Name of Parts and Position.....	4
2.LCD Display.....	5
3.Button Operation.....	5
III. OPERATION INSTRUCTION	7
1.DC Voltage Measurements.....	7
2.AC Voltage Measurements.....	7
3.AC/DC Current Measurements.....	8
4.Diode Tests.....	8
5.Continuity Measurements.....	9
6.Resistance Measurements.....	9
7.Capacitance Measurements.....	10
8.Frequency & RPM Measurements.....	10
9.Temperature Measurements.....	11
IV. MAINTENANCE	11
V. BATTERY & FUSE REPLACEMENT	12
VI. SETUP TestLink	13

Read First: Safety Information

- Never use the meter if the meter or test leads look damaged.
- Be sure the test leads and switch are in the correct position for the desired measurement.
- Never measure resistance or test acoustic continuity in a circuit when power is applied.
- Never connect the probe to a voltage source when the test leads are plugged into the uA/mA and 10A input jack.
- Never apply more than rated voltage between any input jack and earth ground.
- Be careful when working with voltages above 60V dc or 30V ac rms. Such voltages pose a shock hazard.
- Keep your fingers behind the finger guards on the test probes when making measurements.
- To avoid false readings, replace the battery immediately, when  symbol appears.
- In order to protect the tester, the testing should not last longer than 30 seconds when the measuring current is greater than 10A. Allow at least 2 minutes between measurements for the meter to cool down .

Symbols

 Safety Information, Refer to the manual.

 Dangerous Voltage May Be Present.

 Meter is protected throughout by double insulation or reinforced insulation.

When servicing, use only specified replacement parts.

 Comply with IEC1010-1 1000V CATIII

I. SPECIFICATIONS

1. General information

Environment conditions:

- Installation Categories III
- Pollution Degree 2
- Altitude up to 2000 meters
- Indoor use only
- Relatively humidity: 80%RH max.
- Operation Ambient temp: 0~40°C

Maintenance & Clearing:

Repairs or servicing not covered in this manual should be performed only be done by qualified personal.

Periodically wipe the case with a dry cloth. Do not use abrasives detergents, or solvents on this instrument.

Display:

Digital: 4000 counts

Analog: 41 segments

Sampling Rate:

Digital: 2 times/sec

Analog: 20 times/sec for Bargraph indication.

Over Range Indication: LCD will show "OL"

Low battery Indication:

The  is displayed when the battery must be replaced.

Battery type: 9V, NEDA1604 or IEC6F22 or JIS006P

Battery Life: 100hrs typical (alkaline Battery)

Polarity: "  " indicates negative input.

Auto Power Off Time: 30 minutes

Operating Temperature and Humidity:

0°C to 40°C (32°F to 140°F) below 80% RH

Storage Temperature and Humidity:

-10°C to 60°C (14°F to 140°F) below 70% RH

Electromagnetic Compatibility:

Vac and Aac only: RF field = 3V/m

Total accuracy = specified accuracy + 2.0% of range

Safety: 1000V CAT III Regulation EN61010: Part 1: 1993

Certification: **CE**

Dimensions (L x W x H):

Meter: 198 x 86 x 38mm (7.8" x 3.4" x 1.5")

With holster: 209 x 94 x 48mm (8.2" x 3.7" x 1.9")

Weight: Approx. 430g (15.2 oz)

With holster: Approx.600g (21.3oz)

Accessories:

Test leads, Battery, Instruction manual, Temperature Converter, K-type bead Temperature probe, Holster, RS-232 Cable, Software.

2. Electrical Specifications

Accuracy specification:

±([...% of reading]+[...number of least significant digits]) at 18°C to 28°C (64°F to 82°F) $\geq 80\%$ RH

True RMS for ACV and ACA, accuracy are specified from 5% to 100% of range, accuracy add ((1.0%rdg) for crest factor 1.4<C.F<3 at full scale & CF<6 at half scale.

DC Voltage(Auto Range)

Range	Resolution	Accuracy	Input Impedance	Overload protection
400mV	0.1mV	0.3%+2	$\approx 100M\Omega$	1200V _{peak}
4V	1mV	0.3%+2	10M Ω	1200V _{peak}
40V	10mV	0.3%+2	10M Ω	1200V _{peak}
400V	100mV	0.3%+2	10M Ω	1200V _{peak}
1000V	1V	0.5%+2	10M Ω	1200V _{peak}

AC Voltage(Auto Range)

Range	Resolution	Accuracy		Input Impedance	Overload protection
		45Hz-500Hz	500Hz-1KHz		
400mV	0.1mV			$\approx 100M\Omega$	1200V _{peak}
4V	1mV	0.5%+5	1%+5	10M Ω	1200V _{peak}
40V	10mV	0.5%+5	1%+5	10M Ω	1200V _{peak}
400V	100mV	0.5%+5	1%+5	10M Ω	1200V _{peak}
750V	1V	0.8%+5	1.2%+5	10M Ω	1200V _{peak}

Diode Tester

Range	Resolution	Accuracy	Test Current	Test Voltage	Overload protection
	1mV	1%+2	<1mA	<3.5V	600V _{rms}

Continuity beeper

Range	Active Range	Test Voltage	Overload protection
	under40 Ω	<-1.5V	600V _{rms}

DC Current(uA,mA,Auto Range)

Range	Resolution	Accuracy	Burden Voltage	Overload protection
400uA	0.1uA	0.8%+2	< 0.25Vrms	0.5A/600V Fast Blow Fuse
4000uA	1uA	0.8%+2	< 1Vrms	0.5A/600V Fast Blow Fuse
40mA	10uA	0.8%+2	< 0.25Vrms	0.5A/600V Fast Blow Fuse
400mA	100uA	0.8%+2	< 1.5Vrms	0.5A/600V Fast Blow Fuse
20A	10mA	1.0%+2	< 1Vrms	15A/600V Fast Blow Fuse

AC Current(uA,mA,Auto Range)

Range	Resolution	Accuracy		Burden Voltage	Overload protection
		45Hz-500Hz	500Hz-1KHz		
400uA	0.1uA	1.3%+5	1.6%+5	< 0.25Vrms	0.5A/600V Fast Blow Fuse
4000uA	1uA	1.3%+5	1.6%+5	< 1Vrms	0.5A/600V Fast Blow Fuse
40mA	10uA	1.3%+5	1.6%+5	< 0.25Vrms	0.5A/600V Fast Blow Fuse
400mA	100uA	1.3%+5	1.6%+5	< 1.5Vrms	0.5A/600V Fast Blow Fuse
20A	10mA	1.5%+5	1.8%+5	< 1Vrms	15A/600V Fast Blow Fuse

Ohms(Auto Range)

Range	Resolution	Accuracy	Test Voltage	Overload protection
400Ω	0.1Ω	0.6%+2	< 1.5Vdc	600Vrms
4KΩ	1Ω	0.6%+2	< 1.5Vdc	600Vrms
40KΩ	10Ω	0.6%+2	< 1.5Vdc	600Vrms
400KΩ	100Ω	0.6%+2	< 1.5Vdc	600Vrms
4MΩ	1KΩ	0.6%+2	< 1.5Vdc	600Vrms
40MΩ	10KΩ	1%+3	< 1.5Vdc	600Vrms

Frequency(Auto Range)

Range	Resolution	Accuracy	Sensitivity	Overload protection
4KHz	1Hz	0.05%+1	< 1Vrms	600Vrms
40KHz	10Hz	0.05%+1	< 1Vrms	600Vrms
400KHz	100Hz	0.05%+1	< 1Vrms	600Vrms
4MHz	1KHz	0.05%+1	< 3Vrms	600Vrms
40MHz	10KHz	0.05%+1	< 10Vrms	600Vrms

Temperature(°C/°F)

Range	Resolution	Accuracy	Overload protection
°C	1°	0°C~1000°C:(1%+3dgts)	600Vrms
		-50°C~0°C:(1%+4dgts)	
°F	1°	32°F~1832°F:(1%+6dgts)	600Vrms
		-58°F~32°F:(1%+8dgts)	

RPM(Auto Range)

Range	Resolution	Accuracy	Sensitivity	Overload protection
40K RPM	0.01K RPM	0.05%rdg+1dgt	< 1Vrms	600Vrms
400K RPM	0.1K RPM	0.05%rdg+1dgt	< 1Vrms	600Vrms
4M RPM	1K RPM	0.05%rdg+1dgt	< 1Vrms	600Vrms
40M RPM	10K RPM	0.05%rdg+1dgt	< 3Vrms	600Vrms
400M RPM	100K RPM	0.05%rdg+1dgt	< 10Vrms	600Vrms

→ Capacitance(Auto Range)

Range	Resolution	Accuracy	Overload protection
4nF	1PF	1.9%rdg+20dgts	600Vrms
40nF	10PF	1.5%rdg+10dgts	600Vrms
400nF	100PF	1.5%rdg+10dgts	600Vrms
4uF	1nF	1.5%rdg+10dgts	600Vrms
40uF	10nF	1.9%rdg+10dgts	600Vrms
400uF	100nF	1.9%rdg+10dgts	600Vrms
4mF	1uF	1.9%rdg+10dgts	600Vrms
40mF	10uF	3%rdg+10dgts	600Vrms

II. SYMBOL DEFINITION & BUTTON LOCATION

1. Name of Parts and Position

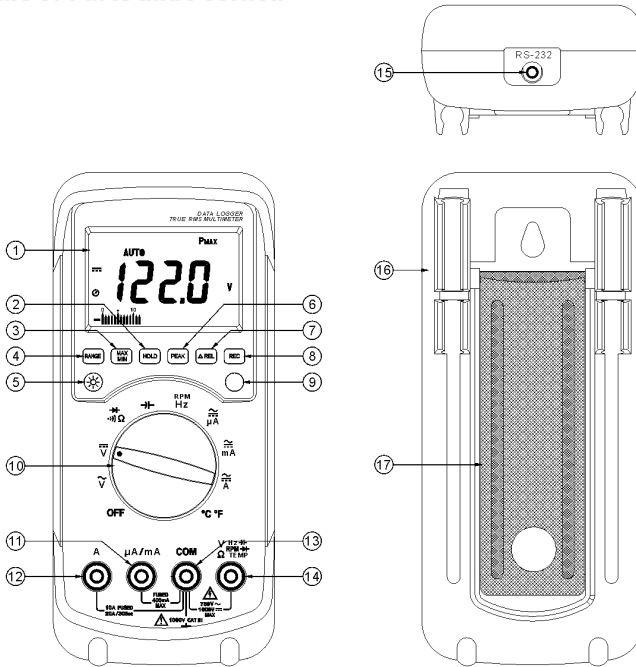

- | | | |
|--------------------------|-------------------------|-------------------------------|
| ① LCD Display | ⑦ Relative Button | ⑬ "COM" Terminal |
| ② Hold Button | ⑧ Record Button | ⑭ "VΩHzTemp" Terminal |
| ③ Maximum Minimum Button | ⑨ Shift Function Button | ⑮ "RS-232" Interface Terminal |
| ④ Range Button | ⑩ Function Select Dial | ⑯ Holster |
| ⑤ Back-light Button | ⑪ "uA/mA" Terminal | ⑰ Tilt Stand |
| ⑥ Peak Hold Button | ⑫ "Amp." Terminal | |

2. LCD Display

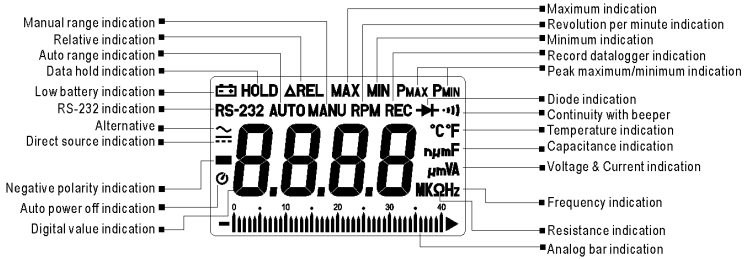

3. Button Operation

■ **REL** Relative Button

Press **REL** button to enter the relative mode. The display is zeroed, and the reading is stored as reference value for subsequent measurements. Press it again, the "ΔREL" indicator blinks and the stored relative value will displayed. Press and hold down **REL** button for 1 second to exit the relative mode.

■ **RANGE** Auto-range & Manual Range Button:

- * Press **RANGE** to select the Manual Range mode and the "MANU" indicator will turn on and the meter remains in the same range it was.
- * In the Manual Range mode, each time you press **RANGE** button, the range (and the input range indicator) increases, and a new value is display.
- * If the meter is in the highest range, pressing the **RANGE** button again will select the lowest range. To exit the Manual Range mode and return to the Auto Range mode, press and hold **RANGE** for one second. The "AUTO" indicator will turn back on.

■ **MAX/MIN** recording button:

Press the **MAX/MIN** button to enter the maximum and minimum recording mode. Select the proper range before using MAX/MIN to ensure that reading value will not exceed the measurement range. Press the button once to select MAX value. Press it again to select MIN value. Press it again to select current value with the "MAX/MIN" indicator blinking. Press and hold down **MAX/MIN** button for one second to exit the MAX/MIN mode.



■ **AC/DC** Current Select and **Ω/Ω⁺/→**Select and **°C/°F**Select and **Hz/RPM** Select Button:

- *To select function AC or DC in current ampere range.
- * To select continuity measurements or Resistance or Diode measurement at **Ω Ω⁺ →** range.
- *To select temperature °C or °F measurement.
- *To select function frequency (Hz) or RPM measurement.

■ **Back-light** Button:

Pressing the **Back-light** button will turn the meter and back-light on. Press the **Back-light** button again to turn off back-light. The back-light will also be turned off automatically after 30 seconds to extend battery life.

▪ **Record Datalogger  Button:**

Press the  button, to start recording. The "REC" and "RS-232" indicators are displayed. Pressing the  button again will stop recording. To clear memory, press the  button while powering up the meter. The "REL" indicator will blink and memory will be erased.

▪ ** Data Hold Button:**



At any time, press the  button to hold the displayed data. Release the held data by pressing it again.

▪ ** Peak Hold Function Button:**

This meter is built with 1 ms peak hold function at ACA, ACV and DCV, DCA range.

Before performing a peak hold operation, first perform a calibration.

To invoke the calibration operation, press and hold the  button for 2 seconds. After that "CAL" will display on the LCD and the offset will be calculated and kept in the meter.

After the calibration, choose Pmax or Pmin by pressing  button to keep the peak reading. Pressing the  button for 2 seconds will return the meter to normal operation.

Once the function range is changed, the meter will need another calibration for peak measurement.

▪ **Function Selector Switch:**

Power OFF and selection of desired function range.

▪ **COM Measuring Connector:**

Connect negative lead (black test lead) for all function measurement.

▪ **20A Measuring Connector:**



Connect positive lead (red test lead) for current measurement below 10A continuous; 20A for 30 seconds maximum

▪ **V Ω , Hz, \rightarrow , \rightarrow , RPM, TEMP Measuring Connector:**

Connect positive lead (red test lead) for voltage, Diode, Frequency, RPM, Capacitance, Temperature, Resistance and Continuity measurement.

▪ **Auto Power Off:**

The meter shuts automatically after 30 minutes if no operations are performed.

To disable the automatic power-off feature, press the  button and keep it pressed while powering up the meter and the  indicator will not be displayed.

▪ **Tilt stand**

▪ **RS-232 Interface:**

The RS-232 signal output is a 9600 bps N81 serial interface.



III. Operation Instruction

1. DC Voltage Measurements:

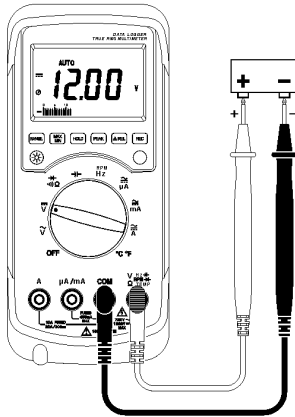

WARNING

Maximum Input Voltage is 1000VDC, 750VAC. Do not attempt to take any voltage measurement that may exceed to avoid electrical shock hazard an/or damage to this instrument.

1. Connect the red test lead to " V " jack and black test lead to "COM" jack.
2. Set range switch to V --- range.
3. Connect the test leads in parallel to the circuit being measured.
4. Read the Voltage value on LCD.

2. AC Voltage Measurements:

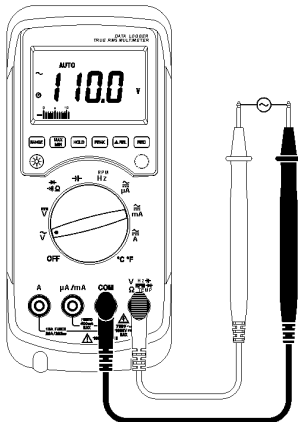

WARNING

Maximum Input Voltage is 1000VDC, 750VAC. Do not attempt to take any voltage measurement that may exceed to avoid electrical shock hazard an/or damage to this instrument.

1. Connect the red test lead to " V " jack and black test lead to "COM" jack.
2. Set range switch to V \sim range.
3. Connect the test leads in parallel to the circuit being measured.
4. Read the Voltage value on LCD.

3. AC/DC Current Measurements:

⚠ WARNING

To avoid injury, do not attempt a current measurement if the open circuit voltage exceeds the rated voltage of the meter.

1. Connect the red test lead to the "mA/ μ A" jack for current measurements up to 400mA. (for measuring current between 400mA to 20A, connect the red test lead to "A" jack). Connect the black test lead to "COM" jack.
2. Set the range selector switch to desired A range and press DC/AC button to select AC/DC function.
3. Cut the power to the circuit to be tested and connect the instrument in series with the circuit with the black test lead on the negative "-" side and the red lead on the positive "+" side being measured.
4. Apply power and read the ampere value on LCD.

Note:

When performing current measurements, to avoid blowing an input fuse, use the 10 A jack until you are sure that the current is less than 400mA.

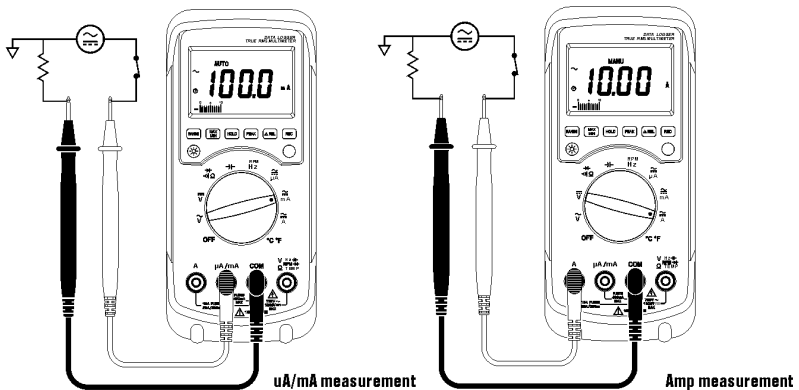

4. Diode Tests

⚠ WARNING

Before taking any in-circuit measurement, remove power from the circuit being tested and discharge all capacitors in the circuit.

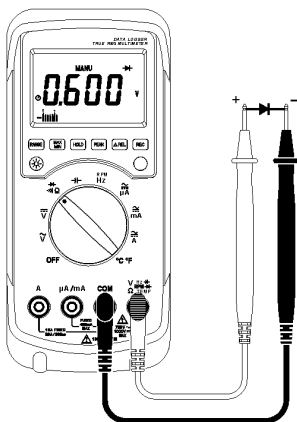

1. Connect the red test lead to "→" jack and black test lead to "COM" jack.
2. Set the range selector Switch to "→" range.
3. Connect the red test lead to the anode side and black test lead to the cathode side of the diode being tested.
4. Read forward Voltage (V_f) value on LCD.
5. If the polarity of test leads are reversed with the diode polarity, the digital reading displays "OL". This can be used for distinguishing the anode and cathode terminals of a diode.

5. Continuity Measurements:

⚠ WARNING

Before taking any in-circuit measurement, remove power from the circuit being tested and discharge all capacitors in the circuit.

1. Connect the red test lead to "Ω" jack and black test lead to "COM" jack.
2. Set the Range Switch to "Ω" range.
3. Connect test leads to the circuit being measured.
4. When the impedance between the test leads is less than 40Ω , it will activate a continuous beeper.

Note: Continuity Test is available to check open/short of the circuit.

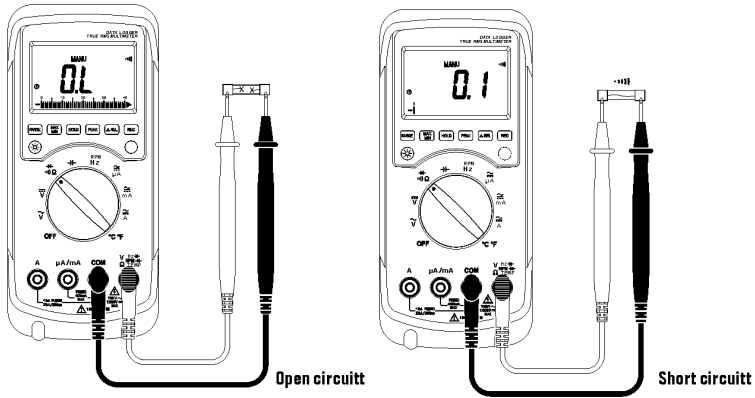

6. Resistance Measurements:

⚠ WARNING

Before taking any in-circuit measurement, remove power from the circuit being tested and discharge all capacitors in the circuit.

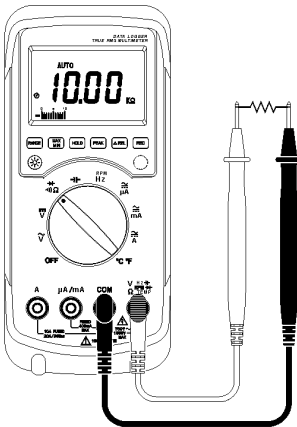

1. Connect the red test lead to "Ω" jack and black test lead to "COM" jack.
2. Set the Range Switch to "Ω" function.
3. Connect the test leads to the circuit being measured and read the resistance value on LCD.

7. Capacitance Measurements:

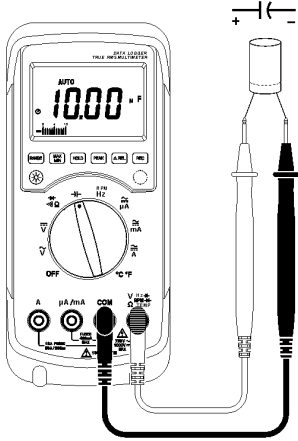

⚠ WARNING

To avoid damage to the meter, disconnect circuit power and discharge all capacitors before measuring capacitance. Use the DC voltage function to confirm that the capacitor is discharged.

1. Connect the red test lead to "4mF" jack and black test lead to "COM" jack.
2. Set the range switch to "4mF" function.
3. Connect the tips of the test leads to the capacitor being tested.
4. Read the capacitance value on LCD.

Note:

- a. The bar graph is disabled in capacitance measurement mode. However, at 4mF and 40mF range, the bar graph is used to display the time remaining to complete measurement.
- b. To obtain an accurate reading, a capacitor must be discharged before measurement begins. The meter will automatically discharge the capacitor. In discharge mode, the LCD display "dISC", but discharging through the meter is quite slow. We recommend discharging the capacitor by some other means.

8. Frequency & RPM Measurements:

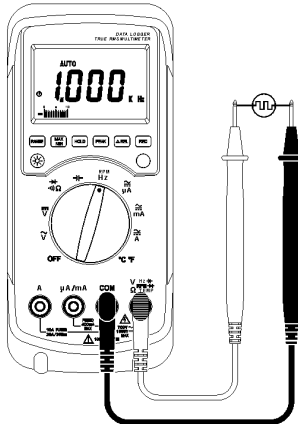

1. Connect the red test lead to "Hz" jack and black test lead to "COM" jack.
2. Set the Range Switch to "Hz" or RPM range by pressing button.
3. Connect the test leads in parallel to the circuit being measured.
4. Read the frequency or RPM value on LCD.

9. Temperature Measurements

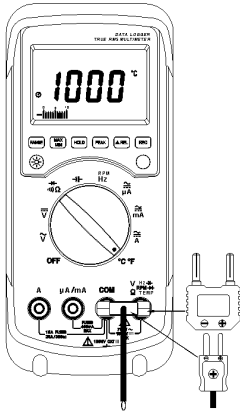

1. Set the range switch to °C °F function.
2. Insert the banana plug K-type temperature bead probe with correct "+" "-" polarities.
3. Press the blue key to select desire °C or °F unit.
4. Read the temperature value on LCD.

IV. MAINTENANCE

⚠ WARNING

To avoid electric shock, remove the test leads before opening the case, and close the case before using the meter.

To prevent fire and possible arc-flash, use fuses with ratings shown on the back of the meter.

⚠ CAUTION

To avoid contamination or static damage, do not touch the circuit board without proper static protection.

V. BATTERY & FUSE REPLACEMENT

⚠ WARNING

To prevent electrical hazard or shock, turn off multimeter and disconnect test leads before removing back cover.

1. Set the range switch to " OFF " position .Use a screwdriver to remove the 5 screws as show in Fig 1.
2. Place the front panel face up.
3. Take out the battery and replace with one new 9V battery, type 1604A.
4. Replace back the front cover and secure it with the original screws.

⚠ WARNING

For safety , use exact replacement .

Fuse 1 : F0.5A / 600V 10 ϕ \times 38 mm Fast blow type

Fuse 2 : F15A / 600V 10 ϕ \times 38 mm Fast blow type

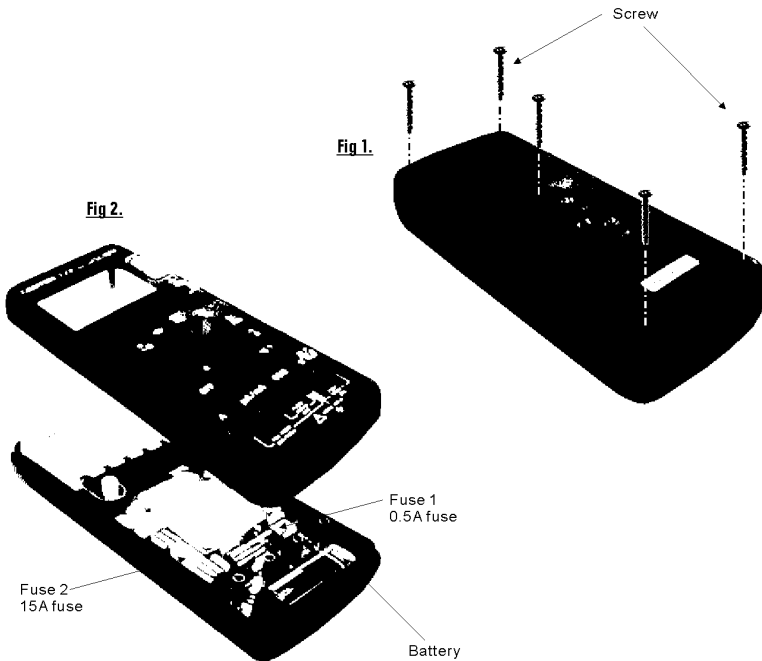

VI. Setup TestLink (Multimeter) – RS232 interface software:

- **The TestLink package contains:**
 1. Two 3.5" diskettes
 2. Custom designed RS232 cable for TestLink.
- **System Required:**
Windows 95 or Windows 98 or Windows NT 4.0.
- **Minimum Hardware Required:**
486-100 MHz PC compatible , or above 16 MB RAM ;
At least 5 MB hard disk space available to install TestLink program. Recommended display resolution is 800X600 or above.
- **Install TestLink:**
 1. We recommend closing all other applications before installing TestLink.
 2. Insert setup diskette 1 to floppy disk drive A.
 3. Choose the Start button on the Taskbar and select Run.
 4. Type A:\SETUP and choose OK. The SE120.exe (executable file) and help files will be copied to your hard disk (default is c:\program files\TestLink\SE120).

1.Run TestLink

Select TestLink | SE120 from "START" menu of Windows, figure 6.1 will display.

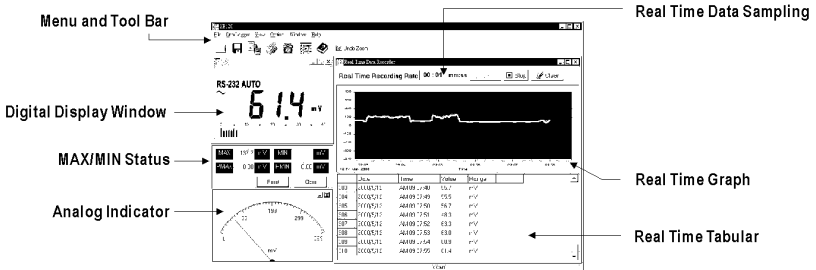



Figure 6-1

2.Real Time Tabular and Real Time Graph.

Select Run from menu or press  from the tool bar of Real Time Graph window to begin real time data collection from multimeter.

You can change the data interval by editing the sampling rate box on the right hand side of Real Time Graph window (see figure 6-1).

3. DataLogger

Select DataLogger from menu to download recorded data from the multimeter. There will be a progress bar showing how many bytes should be loaded and how many bytes have been received. When data is loaded successfully the Datalogger window will be displayed. (See figure 6-2)

Data Sets- Display how many data sets were loaded and the detailed information for each data set (start date, start time, recording rate and data length). Click any data set to select the set for graphing and display in the tabular list.

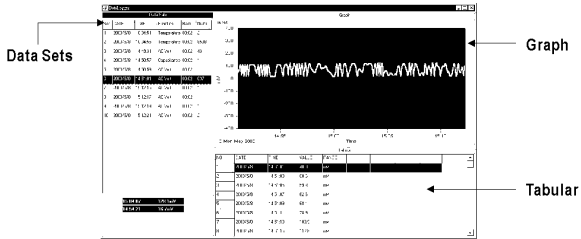

Figure 6-2

4. For other operating instructions, please refer to the on-line help while executing TestLink.



MARTEL ELECTRONICS

E-Mail: sales@martelcorp.com

Web: <http://www.martelcorp.com>



122-0201
